

# Typical HDTV Large Residential System Diagram for DISH Network

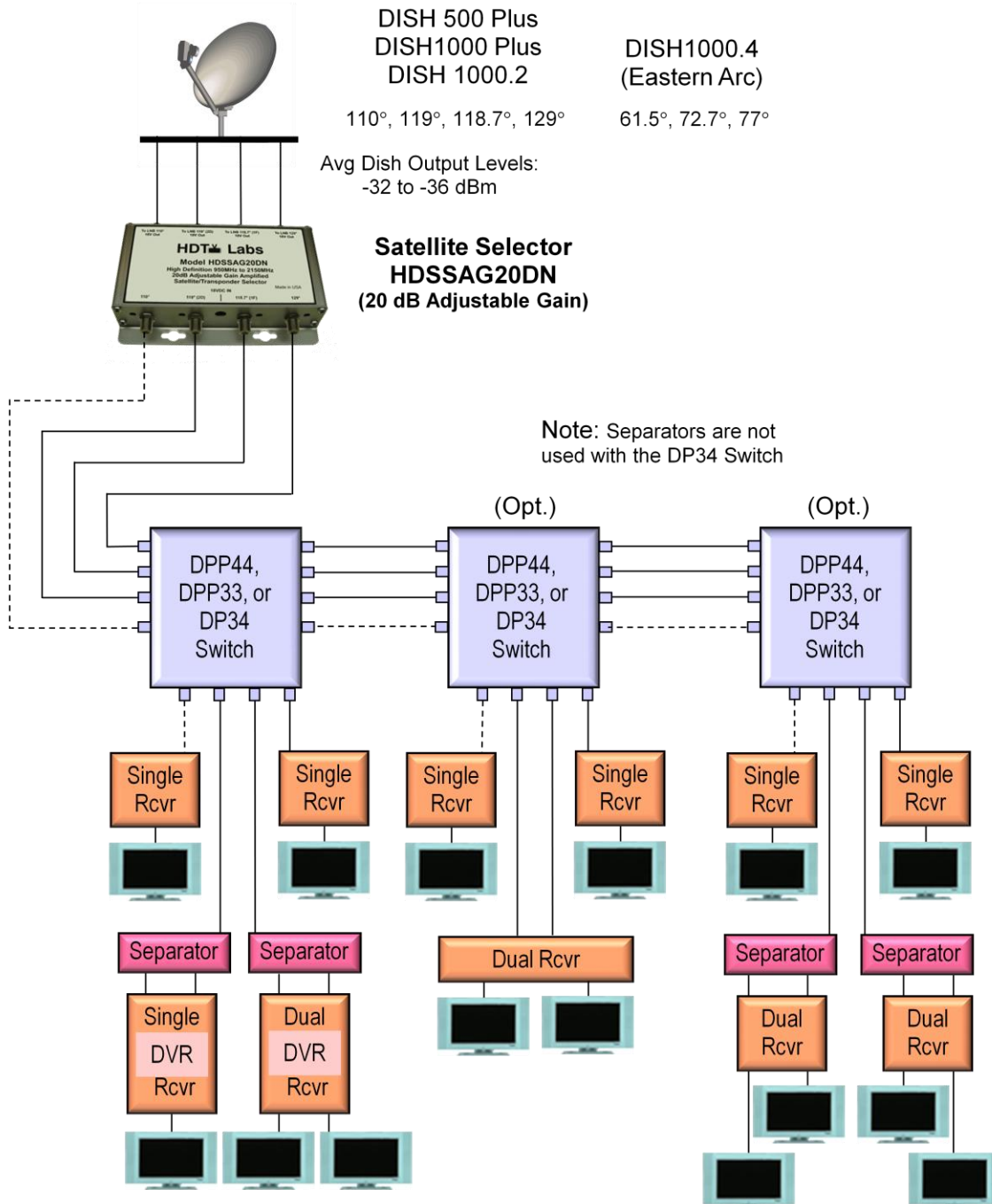

# Typical HDTV Large Residential System Description for DISH Network

## DISH ANTENNAS

The DISH Network dishes used in most large residential installations are typically 1 meter or less in diameter, to comply with zoning restrictions by home owner associations and city ordinances. Determining which dish to deploy will depend upon how many and which satellites you would like to receive. The DISH 500 Plus (110°/118.7°/119°), DISH 1000.2 (110°/119°/129°), or DISH 1000.4 (61.5°/72.7°/77°), should be used for three satellite reception. The DISH 1000 Plus (110°/118.7°/119°/129°) is a four satellite dish. The average output power of all residential dishes varies from approximately -32 dBm to -36 dBm, depending upon orbital slot, transponder power, and location. Recommended RG-6 coaxial cable will have a loss of about 10dB per 100' at 2150MHz, when the connectors and ground blocks used are rated to 2GHz.

## SATELLITE SELECTOR

Since most large residential installations will have more signal loss due to the addition of, multi-switches, more cable runs, and possibly splitters (if not cascading multi-switches) in the system design, a Satellite Selector should be used to optimize system performance. The **20dB Adjustable Gain Satellite Selector (HDSSAG20DN)** is a combination of four power inserters, a 20dB adjustable gain amplifier, and independent power supply that ensures strong and consistent DC voltage levels to the dish LNBS and adds signal strength to the system.

DISH Network residential installations are designed around drop lengths up to 250 feet. The multi-switches are designed to receive signal levels identical to that of a receiver and the parameters thus are the same. This means that the installer should hit the input of a switch within the -30 to -55 dBm window. However, as it is necessary to meet this same window at a receiver, the drop length from the switch needs to be considered. If the level at the switch is at the low end of -55 dBm and drop lengths are of concern, the Satellite Selector should be used to reduce the potential of outages and bring levels back into the required input window range.

Use the Adjustable Gain Satellite Selector to more accurately tune each of the four system channels and maximize the multi-switch output levels to the highest C/N ratio possible. Connections from the dish LNBS can be to any of the four Satellite Selector input ports. Unused channels on the Satellite Selector do not require termination. The Adjustable Gain Satellite Selector allows you to build more reliable systems, use fewer parts, and produce a cleaner C/N output on all channels.

## **MULTI-SWITCHES**

Cascading multi-switches in a large residential installation will provide the option of many more receiver ports being available. The two cascadable multi-switches commonly used in large residential installations are the DISH Pro Plus 44 (DPP44) and DISH Pro 34 (DP34). The DISH Pro Plus 33 (DPP33) can also be used, but must be the last switch cascaded since it has no ports to cascade. For reception of three satellites, all three types of multi-switch could be used in any combination, but for four satellite reception, the DPP44 would be the selection to use and cascade. All switches provide satellite TV signals to the inputs of any combination of multiple receivers.

## **SET TOP BOXES, TV'S, AND DVR'S**

DuoDvr VIP 722k and DuoDvr VIP 622 (2 TVs + DVR), VIP 922 DVR and Solo DVR VIP 612 (1 TV + DVR), Duo VIP 222k (2 TVs), and Solo VIP 211k (1 TV) are the current models of set top boxes being used to receive the HD DISH Network signal. The minimum input signal to each device by standards is a level of -55 dBm. However, for peak performance, our recommendation would be to use a stronger input level of -35 dBm to -40 dBm. This should result in the desired C/N ratio of about 16.

When DISH Pro Plus multi-switches are used, dual tuner and DVR receivers can be connected with a single wire if a DPP Separator is installed at the back of the receiver. This setup will not work, however, if you try to connect two single tuner receivers. The DPP Separator also will not work with DISH Pro multi-switches. For installations not using DPP multi-switches or separators, a single wire from the multi-switch is required for each receiver and two wires are required for both dual and DVR receivers.